

# Postmortem Investigation of Power Transformers—Profile of Degree of Polymerization and Correlation With Furan Concentration in the Oil

Thomas Leibfried, *Member, IEEE*, Michael Jaya, Norbert Majer, Michael Schäfer, Manfred Stach, and Stephan Voss

**Abstract**—In this paper, postmortem aging investigations on insulation material of power transformers are presented. A methodology for taking paper samples in a systematical manner and a scheme for calculating an average degree of polymerization (DP) for the entire transformer out of the DP values of the individual paper samples will be shown. The typical DP profile in the axial direction of transformer coils will be explained using calculated distribution of losses within the coils of a 740-MVA generator stepup transformer. Further, correlations between the furan (2-FAL) concentration in the oil and the average DP of the investigated German GSU transformers and grid transformers are derived and compared with existing correlations.

**Index Terms**—Concentration of furans in the oil, degree of polymerization, paper degradation, postmortem aging investigation of power transformers.

## I. INTRODUCTION

A HUGE part of power transformers still in service all over Europe has an age of at least 40 years. Therefore, condition assessment of power transformers can have an enormous impact on the earnings before interest and taxes (EBIT) of a grid operator. The end of life of a power transformer depends, among other parameters, on the condition of the cellulose. Hydrolysis, oxidation, and pyrolysis reduce the chain length of the cellulose molecules and due to the reduced twist of the individual chains, the mechanical strength is reduced. The mechanical strength of cellulose determines to a high degree the short-circuit strength of a power transformer. The average chain length of the cellulose molecules is commonly referred to as the degree of polymerization (DP). According to the literature, a DP value of about 200 and below indicates the end of life of the insulation material [9]. According to investigations of Moser *et al.* [1], both tensile

strength and DP of paper as well as transformerboard decrease exponentially during aging at constant temperature.

The evaluation of DP from paper samples is a well-established method for aging assessment of power transformers [5], [9]. However, paper samples cannot be taken from the most critical points at the upper end of the coils without destroying the transformer. A convenient method for obtaining information about the aging condition of the insulation material is the interpretation of the concentration of furans in transformer oil. “Furans” denotes a group of chemical compounds which are formed by the degradation of cellulose. The most important furans are 2-furaldehyde (2-FAL), 2-acetyl furan (2-ACF), 5-methyl-2-furaldehyde (5-M2F), 2-furfuryl alcohol (2-FOL), and 5-hydroxymethyl-2-furaldehyde (5-H2F). The furanic compounds generated by the aging process are dissolved in the oil to a certain degree [13]. Thus, the concentration of furans in the oil will provide information about the condition of the cellulose if a distinct correlation between DP and furan concentration in the oil exists. Since the furan analysis offers an easy and noninvasive way to obtain valuable information about the condition of solid insulation material in a transformer, several research projects have been carried out in the past in order to establish such a correlation [2]–[5], [9], [13], [14]. In the following equations, some of these correlations are given with 2-FAL in ppm ( $\mu\text{g/g}$ ):

Heisler and Banzer [2]

$$\text{DP} = 325 \cdot \left( \frac{19}{13} - \log_{10}(2\text{FAL}) \right) \quad \text{for } 100 \leq \text{DP} \leq 900. \quad (1)$$

Chendong [3]

$$\text{DP} = \frac{1}{0.0035} \cdot (1.51 - \log_{10}(\text{Furans})) \quad \text{for } 150 \leq \text{DP} \leq 1000. \quad (2)$$

DePablo [4]

$$\text{DP} = \frac{1850}{2\text{FAL} + 2.3} \quad \text{for } 150 \leq \text{DP} \leq 600. \quad (3)$$

However, some of these correlations are based on accelerated aging of paper samples or it is not reported from which location the paper samples were taken and whether the paper samples were taken in a systematical manner out of transformers (e.g., equidistantly in the axial direction).

The model developed by Cheim *et al.* [9] uses transformer-specific design data and is based on 2-FAL data from about 400

Manuscript received May 02, 2012; revised August 23, 2012, December 18, 2012; accepted January 20, 2013. Date of publication March 15, 2013; date of current version March 21, 2013. Paper no. TPWRD-00401-2012.

T. Leibfried and M. Jaya are with the Karlsruhe Institute of Technology (KIT), Karlsruhe, Germany (e-mail: thomas.leibfried@kit.edu; michael.jaya@kit.edu).

N. Majer is with TenneT TSO GmbH, Bayreuth 95448, Germany (e-mail: norbert.majer@tennet.eu).

M. Schäfer is with TransnetBW, Stuttgart 70174, Germany (e-mail: mic.schaefer@enbw.com).

M. Stach is with E.ON New Build & Technology GmbH, Gelsenkirchen 45896, Germany (e-mail: Manfred.Stach@eon.com).

S. Voss is with Siemens AG, Nürnberg 90461, Germany (e-mail: stephan.voss@siemens.com).

Color versions of one or more of the figures in this paper are available online at <http://ieeexplore.ieee.org>.

Digital Object Identifier 10.1109/TPWRD.2013.2245152

transformers installed in Brazil and laboratory experiments of accelerated transformer aging. A further model developed by Myers [5] is applied to transformers with thermally upgraded paper insulation and uses the total concentration of furans (total furans in ppm) and not only 2-FAL

$$DP = 356.1 - 343.8 \cdot \log_{10} (\text{Total Furans}). \quad (4)$$

The concentration of furans in the oil depends not only on the degradation of cellulose but is the result of a variety of processes. There is, on one hand, the generation of furans depending on parameters like the temperature of the insulation system, water content in the paper, oxygen and acid contents in the oil, transformer design, and type of paper [7]–[9] while, on the other hand, furans can disappear due to evaporation in the open-breathing systems or they dissociate with increasing temperature and under oxidizing conditions [9]. Further, similar to water, the main part of furans is located in the paper and only a minor part is dissolved in the oil. The ratio of furans in paper to furans in oil is different for each furanic compound and is additionally temperature dependent [13]. Maintenance activities, such as oil treatments, have a direct impact on the oil and, therefore, on the furan concentration in it. If these dependencies play a key role, the furan analysis can hardly be used for condition assessment of power transformers in practice.

The main aims of the research work presented in this paper are:

- obtaining more knowledge about paper degradation at different locations of the insulation system (conductor insulation and main insulation) of power transformers;
- investigation of correlations between furan concentration in the oil and DP of paper based on paper samples aged under operational conditions in order to realize a more reliable aging assessment of power transformers.

## II. PAPER SAMPLING PROCEDURE

All paper samples used for this investigation were taken during the scrapping procedure of aged power transformers. Therefore, it was possible to take paper samples from the conductor insulation of all coils. The paper sampling procedure is a compromise between costs and time on one hand and scientific accuracy on the other hand. Assuming costs of about 60–100 € for determining the DP of a single paper sample, a total number of 50 samples will cause costs of 3000–5000 €. Thus, much more than 50 to 100 samples in total per transformer will not be reasonable keeping also in mind that these expenditures cover only the DP analyzing procedure. Further costs occur for taking the paper samples in the workshop of the scrapper or in the substation during onsite scrapping. In order to keep the number of samples as low as possible, the following assumptions have been made:

- Due to the symmetry of the load current in all three phases, the conductor temperatures of the three coils at corresponding locations should not vary significantly. Nevertheless, the middle phase (V) was chosen for taking material samples in this study. Usually, the cooling system of large power transformers, which are often OD cooled, is mounted at the end walls of the tank. Thus, a part of

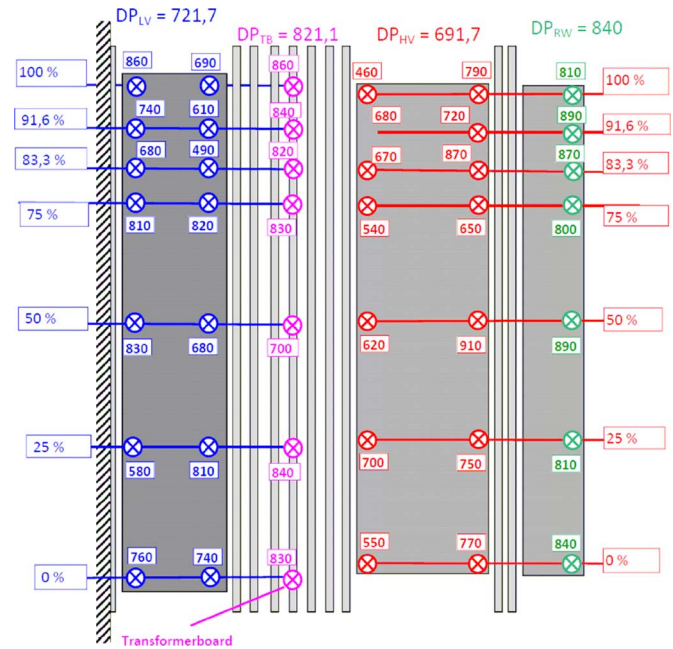

Fig. 1. Paper sampling procedure: Locations for taking samples and results exemplified by a GSU transformer (M 6a in Fig. 3).

the oil pumped into the bottom conduits flows into the outer coils and the other part into the coils of the middle phase. However, there is an additional flow resistance in the bottom conduits from the coils of the outer phases to the middle-phase coils which reduces the pressure of the oil flowing into the middle-phase coils depending on the design of oil conduits. This could result in a somewhat higher thermal stress of the middle-phase coils compared to the coils of the outer phases. Differences in aging of locations facing the tank or neighboring phases are neglected.

- The temperature around the circumference at a certain (constant) height of a coil does not vary very much. Thus, paper samples of the conductor insulation have been taken at one radial position at the inner and outer diameter in case of LV and HV coils and at the outer diameter of the regulating winding, since their width is small compared to widths of the LV or HV coil.

In order to limit the number of paper samples to a reasonable degree, the decision was made to take samples equally spaced in between the lower end (0%) and the upper end (100%) of the coil at 0%, 25%, 50%, 75%, and 100% of the coil height [6]. After a few post mortem investigations, it was found that the DP profile along a coil can show big variations in between 75% and 100% of the coil height. Therefore, two additional sample locations were introduced at 91.6% and 83.3% of the coil height. Taking samples at seven axial positions at 100%, 91.6%, 83.3%, 75%, 50%, 25%, and 0% of the coil height was found to be a good compromise between effort and accuracy of the result (Fig. 1).

Usually, paper samples were taken at the inner and outer diameter of the high-voltage (HV), medium-voltage (MV), and low-voltage (LV) coil, and the width of other coils like regulating winding and tertiary winding are so small that paper

samples were taken only at the outer diameter. In some cases, paper samples have been taken at the inner and outer diameter and additionally from the middle of the coil depending on its width. Thus, for a typical GSU transformer, we obtain  $(1 + 2(3) + 2) * 7 = 35(42)$  and for a typical grid transformer, we get  $(1 + 2 + 2 + 2) * 7 = 49$  paper samples. In some cases, additional samples at the seven axial positions were taken from barriers between HV and LV coil as shown in Fig. 1.

### III. THEORETICAL CONSIDERATIONS

#### A. Calculation of an Average DP of a Coil

Let us make the following thought experiment. We assume that a clear relationship between DP degradation of paper and furan generation exists. Identical paper samples with respect to type and mass are put into 10 different oil vessels and are aged at 10 different temperatures during a certain period of time. Thus, a certain amount of furans is generated in each vessel and the DP of the paper decreases down to 10 different final values. After the ageing process, the oil is filled into a large vessel and the average furan concentration is determined. It is obvious, that this average furan concentration correlates with the average final DP values of all paper samples but not directly to the lowest DP value of the paper found in the vessel with highest temperature. Transferring this thought experiment to a power transformer would mean that the furan concentration can only be correlated to an average DP of an infinite number of paper samples and not to the lowest DP found in a transformer.

The next step is to come from an infinite number of paper samples to a feasible number of samples in practice. Assuming there are DP values from a very large number of locations along the coil available, choosing equidistantly the same number of samples from the upper half and the lower half of the coil beginning from the middle of the coil (50%) for the calculation of an average DP value of the coil seems to be reasonable approach (Fig. 2). However, the number of samples is limited. Thus, beginning from the coil middle at 50%, corresponding sample locations were chosen such as 25%–75% and 0%–100%. The corresponding locations for 91.6% and 83.3% are 8.3% and 16.6%, respectively. Many of the investigated transformer coils show a nearly linear behavior of DP values in between 0% and 25% of the coil length as shown in Fig. 4(b). Thus, the DP values for the locations at 8.3% and 16.6% of the coil length can be calculated on the basis of measured values at 0% and 25% of the coil length by linear interpolation

$$\begin{aligned} DP(8,3) &= DP(0) + \frac{DP(25) - DP(0)}{25} \cdot 8,3 \\ &= DP(0) + \frac{DP(25) - DP(0)}{3} \\ DP(16,6) &= DP(0) + \frac{DP(25) - DP(0)}{25} \cdot 16,6 \\ &= DP(0) + 2 \cdot \frac{DP(25) - DP(0)}{3}. \end{aligned} \quad (5)$$

Fig. 2 shows the sample locations along a coil used for the investigation presented in this paper as well as the principle of calculating the DP values at 8.3% and 16.6% of the coil length. Using the experimentally determined DP values at 100%,

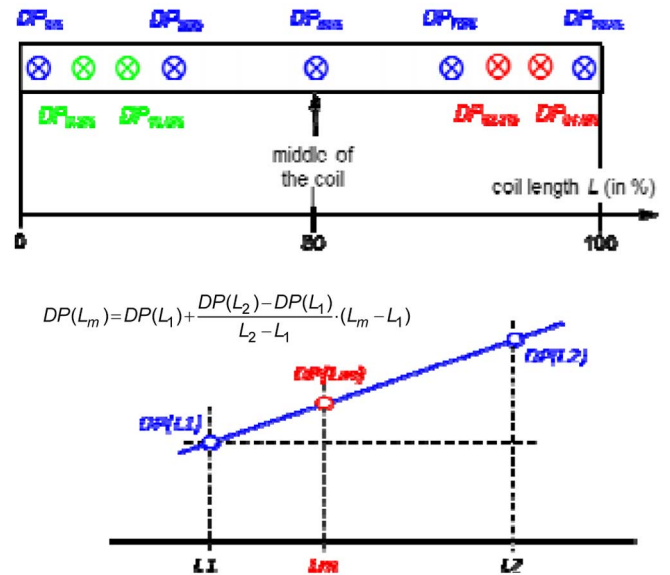

Fig. 2. Paper sampling procedure: Locations for taking samples along a transformer coil and interpolation scheme for calculating an unknown  $DP(L_m)$  at the location  $L_m$  out of  $DP(L_1)$  at  $L_1$  and  $DP(L_2)$  at  $L_2$ .

91.6%, 83.3%, 75%, 50%, 25%, and 0% of the coil length and the values at 8.3% and 16.6% calculated according to (5), the average DP value of the coil is calculated by

$$\begin{aligned} \overline{DP}_{\text{coil}} &= \frac{1}{9} \cdot \{DP(50) + DP(100) + DP(0) \\ &\quad + DP(75) + DP(25) \\ &\quad + DP(91.6) + DP(8.3) \\ &\quad + DP(83.3) + DP(16.6)\}. \end{aligned} \quad (6)$$

#### B. Calculating an Average DP of the Entire Transformer

The calculated average DP of the entire transformer shall be correlated with the furan concentration in the oil. Basically, all parts of the insulation system which could produce furans have to be taken into consideration for the calculation of the average DP. As shown in Fig. 1 at the example of a transformerboard barrier in between the HV and LV coil, all insulation parts which have no direct contact to the heat source (the copper conductor of coils) usually have a much higher DP than the insulation paper of the copper conductor. This justifies the following assumptions and helps to simplify the determination of an average DP for the entire transformer:

- “cold” insulation parts like pressboard and wooden block generate little amount of furan, so their contribution to total furan generation can be neglected and, as a consequence:
- only the insulation paper of the copper conductors generates furans to a noteworthy degree.

The easiest way of calculating an average DP of the entire transformer for comparison with the concentration of furans in the oil as an overall result of paper degradation is to sum up the average DP values of all coils (RW: regulating winding, HV: HV winding, ...) and divide this by the number of coils ( $N_{\text{coils}}$ ):

$$DP_{\text{av}} = \frac{\overline{DP}_{\text{RW}} + \overline{DP}_{\text{HV}} + \dots + \overline{DP}_{\text{LV}}}{N_{\text{coils}}}. \quad (7)$$

Type	manu- factured	age [years]	ratio [kV/kV]	S [MVA]	DP <sub>min</sub>	DP <sub>LV</sub>	DP <sub>MW</sub>	DP <sub>HV</sub>	DP <sub>RW</sub>	DP <sub>av</sub>	DP <sub>av</sub> - DP <sub>min</sub>	Furans [ppm] 2-FAL	others
<b>Generator step-up transformers (GSU's)</b>													
M 1	1970	35	107/10,5	110	90	166	-	334	-	250	160	2,2	5M2F 0,08 2FOL 0,08
M 2	1970	35	235,8/21	380	70	212,7	-	225,1	-	218,9	149	4,53	bdl
M 3	1981	27	110/65	200	515	576,4	-	622,7	579,9	584,3	69	0,63	5H2F 0,06 2FOL 0,06
M 4	1967	42	245/21	360	139	594	-	504	811	636	497	0,24	bdl
M 5	1976	33	430/27	740	240	691	-	519	-	605	365	0,43	bdl
M 6a	1974	35	420/27	740	460	721,7	-	691,7	840	733,3	273	0,25	bdl
M 6b	1974	36	420/27	740	460	735,6	-	700	828,3	746,8	287	0,3	bdl
M 7	1970	40	107/10,5	90	240	431,7	-	522,2	603,9	519,3	279	1,68	bdl
<b>Grid transformers</b>													
N 1	1964	42	110/22	23	729	845	-	914	966,2	879,5	151	0,1	bdl
N 2	1962	47	105/21	25	647	739,6	-	886,3	890,1	838,3	191	0,107	bdl
N 3	1973	33	104,89/ 22	40	610	747,8	-	837,4	900	792,6	183	0,05	bdl
N 4	1988	19	400/120/30	300	820	879,9	952,6	994,7	-	942,4	122	0,06	bdl
N 5	1967	40	220/66/ 10,5	100	490	683,1	-	696,4	-	689,7	200	0,11	bdl
N 6	1976	31	110/110	200	644	-	695,6	743,7	-	719,7	76	0,07	bdl
N 7	1958	50	105/22,5	31,5	473	668,1	-	764,8	724,2	719	246	0,11	bdl
N 8	1975	35	220/118/21	200	320	-	389	463	474	442	122	1,28	bdl
N 9a	1967	43	400/231/30	110	240	449	524	632	-	535	295	0,96	2FOL 0,05
N 9b	1967	43	400/231/30	110	210	404	578	620	-	534	324	1,13	2FOL 0,05
N 10	1967	44	110/21,5/6,2	25	420	741	-	632	867	747	327	0,38	bdl
N 11	1964	45	240/110/11	200	548	679,8	-	695,2	-	687,5	140	0,66	bdl
N 12	1972	37	240/110/11	200	608	765,8	-	810,3	-	788,1	180	0,81	bdl
N 13	1969	42	240/110/11	200	520	872	684	682	702	689,3	169	1,28	5H2F 0,11 2FOL 0,1
N 14	1972	39	240/110/11	200	550	-	707	686	801	731,3	181	0,88	5H2F 0,16 2FOL 0,1
<b>16.7 Hz transformers (Railway transformers)</b>													
R 1	1964	42	115/10,75	62,5	405	543,9	-	541,9	634,4	542,9	138	0,05	2FOL 0,06
R 2a	1971	36	115/6,6	33,3	85	153,2	-	226,5	-	189,9	105	2,64	5M2F 0,09
R 2b	1971	38	115/6,6	33,3	62	155	-	268	-	223	161	1,49	bdl
R 3a	1971	38	115/6,6	9	113	280,2	-	315	-	297,6	185	2,34	5H2F 0,14 2ACF 0,08
R 3b	1971	36	115/6,6	9	160	265,8	-	371,5	-	318,6	159	3,12	5H2F 0,12 2ACF 0,15
R 3c	1971	37	115/6,6	9	163	281,8	-	372,7	-	327,2	164	3,00	5HMF 0,14

bdl : below detection limit of 0.05 ppm

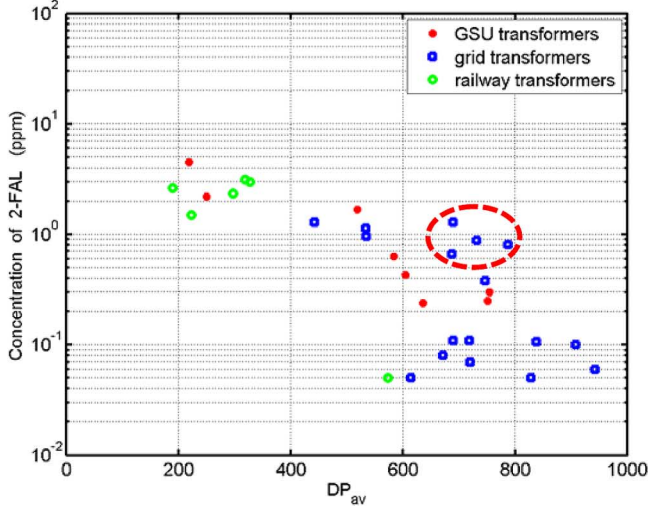

Fig. 3. Entirety of all investigated power transformers sorted into three groups.

Other approaches are conceivable, for example, to weigh the average DP's of the individual coils with their mass of paper, as shown in (8) at the bottom of the page.

The idea behind this approach is that the paper mass determines the contribution of each coil to the generation of fu-

rans, since the more molecule chains can be cracked, the more cracking byproducts can potentially contribute to the furan generation. However, one critical aspect of this approach, besides its validation, is the necessity of the design data of investigated transformers in order to determine the mass of insulation material for each coil. Even in the fortunate case that the manufacturer is willing to provide such data, the authors experienced that blueprints of very old transformers were sometimes incomplete and the required data did not exist. However, in order to realize a consistent data evaluation, it is not possible to weigh the DPs of the individual coils for some transformers but not for all of them. Thus, in practice, the only possible approach is to use (7) for the calculation of an average DP.

#### IV. CORRELATION BETWEEN DP AND FURANS

##### A. Entirety of Investigated Power Transformers

It is well known that failures inside transformers (e.g., hotspots or electrical failures) produce besides failure gases a certain amount of furans [7], [8]. Such transformers would falsify the correlation between average DP and furan concentration in the oil. Therefore, a DGA was performed before the final switch-off of all investigated transformers and when available the historic DGA data have been investigated in order to exclude any failures in those transformers which are used for further evaluation. Fig. 3 gives an overview of the investigated power transformers where no failure was indicated by DGA history. Twin transformers are denoted with "a" and "b" (e.g., M 6a and M 6b).

The diagram (Fig. 3) shows the 2-FAL concentration in oil versus the average DP ( $DP_{av}$ ) for all investigated transformers. The average DP was calculated according to (7). The statistical spread in this diagram could be caused by a number of uncertainties such as:

- errors in the determination of the furan concentration in the oil [15] and the DP of paper samples, as well as:
- the already mentioned dependencies of the furan generation from the insulation system temperature level, the water content in the solid insulation material, oxygen and acid contents in the oil as well as transformer design [6]–[8]. A quantification of some of these parameters is given in [7], [8] on the basis of laboratory experiments. Unfortunately, it is not possible to get historical data of the temperature distribution inside 30 or 40 years old transformers in practice since even basic data like load level are usually not recorded over such a long period of time. Without reliable data of at least the load, even a coarse estimation of an "average operating temperature" of a transformer during its service period is not possible.

There are outliers (transformers N11 to N14) marked by the red circle which obviously do not fit the rest of the pairs. The calculated mean difference between the average DP ( $DP_{av}$ ) and the

$$DP_{av} = \frac{m_{RW} \cdot \overline{DP}_{RW} + m_{HV} \cdot \overline{DP}_{HV} + \dots + m_{LV} \cdot \overline{DP}_{LV}}{m_{RW} + m_{HV} + \dots + m_{LV}} \quad (8)$$



minimum DP ( $DP_{\min}$ ) together with the corresponding standard deviation is

$$\overline{DP_{av}} - DP_{\min} = \begin{cases} 260 \pm 134, & \text{for GSU transformers} \\ 194 \pm 75, & \text{for grid transformers} \\ 151 \pm 27, & \text{for railway transformers} \end{cases} \quad (9)$$

Equation (9) states that a GSU transformer with an average DP of let's say 400 could have a local minimum DP ( $DP_{\min}$ ) of about 140 or even below.

Both, the furanic compounds for diagnosis statistical spread of the correlation between average DP and concentration of furans in the oil as well as the outliers in Fig. 3 led to the idea to define three groups of transformers: generator stepup transformers, grid transformers and railway transformers as shown in Fig. 3. These groups of transformers are usually operated in a very different manner. In Germany, generator stepup transformers of coal-fired and nuclear power stations are often operated at constant load close to their rating whereas grid transformers usually see a varying load typically well below their nominal rating. Railway transformers are often operated at their rating but with considerably varying load.

### B. Generator Stepup Transformers

During the investigation GSU transformers with average DP values in the range of 600 to 750 which were in service since the early 1970's as well as GSU's being in service for the same time with average DP's of about 500 or below 300 were found (Fig. 3). Obviously, the common assumption according to the German experience that the lifetime of a GSU transformer is limited to about 25 years [12] is not true. The ageing of the insulation paper in a GSU transformer depends mainly on the temperature level during operation. Keeping the oil temperature at low level by an appropriate cooling system could be one measure to increase the lifetime of the paper.

Fig. 4(a) shows the DP values of paper samples taken from transformer M5 according to Fig. 3. The HV coil consisted of a twin conductor with a paper insulation thickness of 0.4 mm for each conductor and a thickness of 1.4 mm of the common paper insulation. The first DP values for the HV coil in Fig. 4 are that of the common insulation and the second ones are that of the individual insulation which is close to the conductor. Fig. 4(b) shows the DP profile along the HV and LV coils of transformer M5. Obviously, there is a DP grading within the paper insulation thickness of 1.8 mm. The paper insulation of the individual conductors are closer to the heat source and consequently show lower DP values (blue curve).

The DP profile in axial direction of GSU transformer coils shows in many cases a minimum in between 75% and 100% of the coil length. This gives some evidence that the hotspot is not located at the top of the coil but somewhere within the upper quarter of the coil as shown in Fig. 4(b). The reason for the minimum in the DP profile somewhere below the upper coil end is the temperature distribution inside the coil which is determined by the distribution of losses to a high degree.

The HV coil of transformer M5 has a middle entrance and is designed as a disc winding with flat wires in two sections.

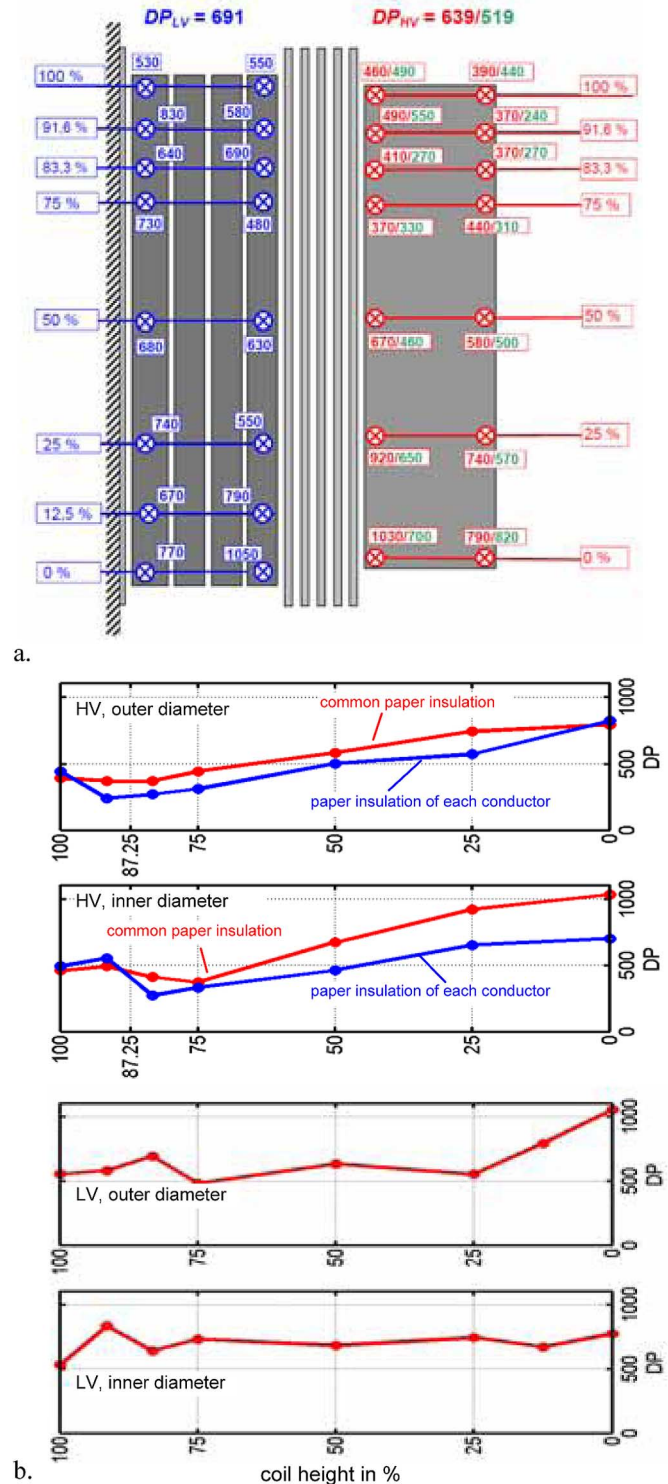

a.

b.

Fig. 4. DP of paper samples taken from transformer M5 according to Fig. 3: (a) DP values of individual paper samples, green DP figures: paper insulation of the individual conductors, red DP figures: common paper insulation of a twin conductor. (b) DP profile along the HV and LV coil.

Section A has 1 wire axial and 2 wires radial in parallel (Fig. 5). Section B has 2 wires axial and 2 wires radial in parallel. The transition from Sections B to A is located at 12.75% and 87.25% of the axial coil height. The LV coil is a single layer with 5 radial

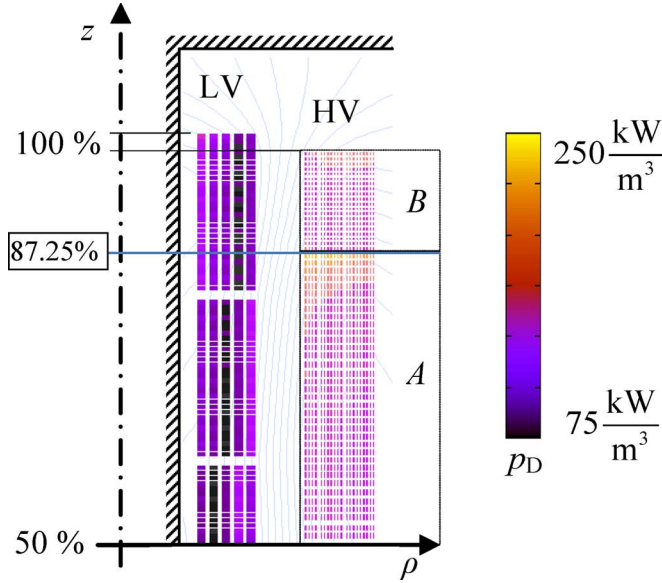

Fig. 5. Distribution winding losses  $p_D$  calculated for transformer M5 in Fig. 3.

CTC (continuously transposed cables) in parallel, 3 axial CTC in parallel and 4 radial sublayer transpositions.

In order to investigate the axial DP profile in detail, the losses occurring in transformer M5 have been determined using a 2-D axisymmetric model applying a boundary element method. For calculation of magnetic field and induction, respectively, boundaries of the core window model are: core diameter, lower and upper yoke, tank wall, where a relative permeability of 200 has been assumed. For field computation, windings have been modeled turn by turn as circular loops, and the current distribution is calculated implicitly coupled in an integrated electrical network representation. Finally, the calculated peak values of axial and radial induction  $B_{\text{peak,ax}}$  and  $B_{\text{peak,rad}}$  at the individual turn locations are used to calculate eddy current losses distribution  $p_{\text{ed}}$  in  $[\text{W}/\text{m}^3]$  according to Kulkarni and Khaparde [9] by

$$p_{\text{ed}} = \frac{N_{\text{str}}\omega^2\sigma}{24} \left[ (H \cdot B_{\text{peak,rad}})^2 + (W \cdot B_{\text{peak,ax}})^2 \right]. \quad (10)$$

In (10),  $N_{\text{str}}$  denotes the number of conductor strands;  $\omega$  is the angular frequency;  $\sigma$  is the electrical conductivity; and  $L$ ,  $H$  and  $W$  are the effective turn length, axial height, and radial width of single strands, respectively. Fig. 5 shows the total losses distribution for the upper 50% of core window height. Light blue lines in Fig. 5 represent magnetic-field lines and, thus, display an increasing radial flux component in the positive  $z$  direction from center to top, especially at HV Section B. Winding losses are slightly higher in the HV flat wires rather than in LV CTC conductors. Highest local losses occur at the top of HV coil Section A since a single axial flat wire with full axial height  $H$  is exposed to almost the same radial magnetic flux than two axial flat wires of half the height ( $H/2$ ) at the bottom of the coil (Section B). The temperature of a coil is determined by the loss distribution and the oil flow in the cooling ducts. Since there is oil flow from bottom to top, the hotspot can be assumed to be somewhere at about 90% to 95% of the HV coil height. Comparing the location of the transition from HV coil Sections A and

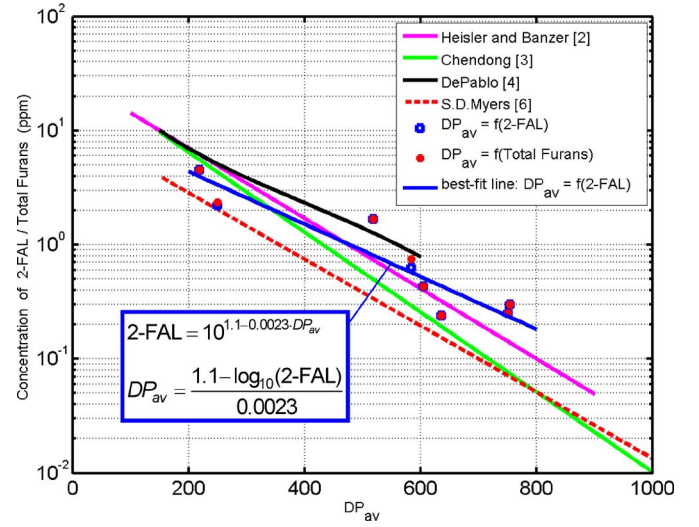

Fig. 6. Correlation between concentration of 2-FAL and total furans in the oil and average DP according to (7) for GSU transformers given in Fig. 3.

B at 87.25% axial coil height and the higher losses at the upper end of coil Section A with the DP profile in Fig. 5(b) (upper figure), it is clearly visible that the position of the winding region with the highest losses is in good accordance with the minimum of the DP profile in the axial direction. Thus, local enhancement of the losses within the coil causes hotspots around these locations and consequently local reduction of the DP.

The empirical correlation coefficient  $R$  between two random variables  $X$  and  $Y$  can be used to describe whether a linear relationship between  $X$  and  $Y$  exists.  $|R| = 1$  means a linear relation exists while  $|R| = 0$  means  $X$  and  $Y$  are uncorrelated. The linear relation between  $DP_{\text{av}}$  and  $\log_{10}(2\text{-FAL})$  of the investigated GSU transformers can be described by (Fig. 6)

$$DP_{\text{av}} = \frac{1.1 - \log_{10}(2\text{-FAL})}{0.0023} \quad \text{for } 200 \leq DP_{\text{av}} \leq 800 \quad (11)$$

with  $|R| = 0.93$ . An uncertainty  $\Delta(2\text{-FAL})$  of the furan concentration and the resulting deviation  $\Delta DP_{\text{av}}$  are given by

$$\begin{aligned} \Delta DP_{\text{av}} &\approx \frac{\partial DP_{\text{av}}}{\partial 2\text{-FAL}} \cdot \Delta(2\text{-FAL}) \\ &= - \left( \frac{189}{2\text{-FAL}} \right) \cdot \Delta(2\text{-FAL}). \end{aligned} \quad (12)$$

Thus, the effect of an uncertain furan reading depends on the furan concentration. The higher the furan concentration, the lower the effect of an uncertainty  $\Delta(2\text{-FAL})$ . Thus, an uncertainty of the measured furan concentration is of less effect for critical transformers with high furan concentrations in the oil and consequently low average DP values.

The linear regression curve (11) roughly follows the correlations of Heisler and Banzer [2], Chendong [3] and De Pablo [4]. Comparing the relation according to (4) used by Myers for the assessment of thermally upgraded paper [5] to the transformer data according to Fig. 3 shows that (4) provides a “worst case” estimation of the average DP which is a useful tool for transformer assessment in practice.

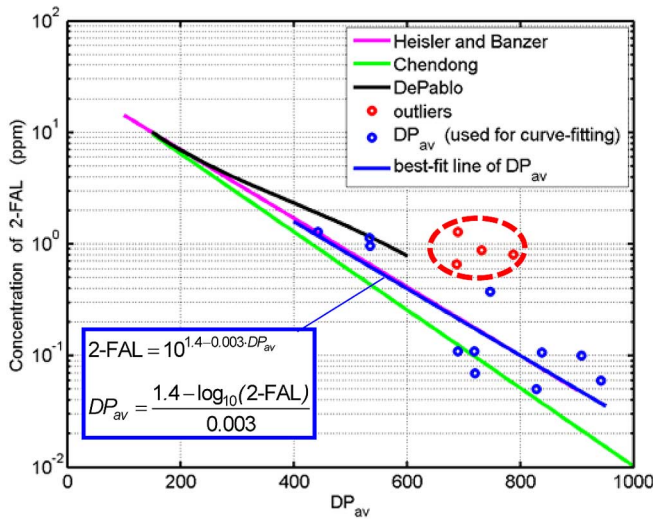

Fig. 7. Correlation between the concentration of 2-FAL in the oil and average DP according to (7) for the grid transformers given in Fig. 3 without using data of transformers N11 to N14.

### C. Grid Transformers

Fig. 7 shows the correlation between average DP and 2-FAL concentration in the oil for the grid transformers given in Fig. 3. The average DP values of all investigated grid transformers are much higher than those of GSU transformers with the same age. In Germany, grid transformers usually do not reach their end of life due to paper degradation as confirmed by the data shown in Fig. 3. During this investigation, 4 grid transformers had comparably high furan concentration in the oil and yet high average DP values. These transformers (N11 to N14 in Fig. 3) are marked with a red ellipse in Figs. 3 and 7. The DGA of these 4 transformers does not give any evidence for a hotspot or any other failure inside those transformers. They were scrapped since the grid operator is gradually upgrading the old 220-kV grid to the 400-kV level. Unfortunately, the oil of these transformers could not be thoroughly investigated. Only on transformer N13 a dielectric measurement (FDS, Frequency Domain Spectroscopy) was performed which provided an oil conductivity of 5.5 pS/m at an oil temperature of +3°C. The conductivity of oil in aged transformers without any conspicuity is below 1 pS at 20°C [11]. Thus, the oil conductivity of transformer N13 was considerably increased, taking into account that oil conductivity increases with increasing temperature. This increase could be caused by either a high moisture concentration in the oil or a high acid concentration in the paper and therefore in the oil. Since the only conspicuity found was a high oil conductivity of transformer N13, it is assumed that the high furan content in the oil of these grid transformers is somehow correlated to the worsened condition of the oil. Further investigations are necessary to study the reason for the high furan concentration in some grid transformers.

Transformers N1 to N10 according to Fig. 3 are used to calculate the following relation between the average DP ( $DP_{av}$ ) and the concentration of 2-FAL (in ppm) in the oil with  $|R| = 0.86$ :

$$DP_{av} = \frac{1.4 - \log_{10}(2-FAL)}{0.003} \quad \text{for } 200 \leq DP_{av} \leq 800. \quad (13)$$

### D. Railway Transformers

According to Fig. 3 only 6 railway transformers were investigated within this study and three of them are of identical type and design. From a statistical point of view the sample size is definitely too small for making any reliable evaluation such as the calculation of a formula for the correlation between average DP of paper and furan concentration in oil.

### V. AGING OF TWINS

The investigation given in Fig. 3 comprises some twin transformers. If the operating conditions are very similar and if there is no failure, e.g., a hotspot, in one of the transformers, the development of average DP and furan concentration in the oil of twin transformers is very similar as shown at the example of M6a/b, N9a/b, R2a/b and R3a/b/c.

### VI. PROCEDURE AND LIMITATIONS OF THE METHOD FOR CONDITION ASSESSMENT

The first step using (11) or (13) for condition assessment is to ensure that there is no failure inside the transformer under test by DGA and measurement of the characteristic oil parameters. If such a failure is detected, the correlation cannot be applied since furans could have been produced by the failure and not by ageing. Furthermore, the measured furan concentration in the oil is influenced by any oil treatment (e.g., replacement or regeneration) or drying of the active part. In the case of free-breathing transformers it can be expected that such effects diminish within about 2 years after those measures were carried out. The same is with furans not generated by paper ageing but being left from oil refinery.

If no failure or any conspicuity is detected, (11) or (13) can be used to estimate the average DP ( $DP_{av}$ ). On this basis, the minimum DP ( $DP_{min}$ ) can be estimated using (9). Nevertheless, the following limitations must be kept in mind:

- The correlations do not provide a precise value. A tolerance of the estimated average DP using (11) or (13) of about  $\pm 100$  has to be taken into consideration.
- For the calculation of  $DP_{min}$  out of  $DP_{av}$  using (9), the standard deviation according to (9) has to be considered.
- The number of investigated transformers is still comparably low for a statistical data evaluation. Thus, minor changes of the given correlations can be expected with increasing sample size.

### VII. CONCLUSION

In this paper, a systematical method for taking paper samples from scrapped power transformers is suggested, together with a methodology for the evaluation of DP values of paper samples, with the aim of obtaining valuable information about the aging condition of a power transformer. Thereby, a grouping into different types of transformers is suggested, since at least in Germany, the operation mode and, therefore, the aging process inside GSU transformers and grid transformers are substantially different. The investigation showed several GSU transformers with rather high average DP values of about 700 after 30 years of service, while others were found with an average DP close to 200 after only 25 years of service. Usually, grid transformers



operating in the German grid do not reach their end of life due to paper degradation even after a service period of up to 50 years.

The profile of the DP in axial direction of a coil is mainly determined by the loss distribution. The hotspot is located in many transformers not at the top of the coil but within the upper quarter of the coil.

For GSU and grid transformers operating in Germany, a formula for calculating an average DP from the 2-FAL concentration in the oil was derived. However, the application of these formulae for power transformer condition assessments does not provide 100% reliable evaluation but they allow a ranking of transformers. The number of investigated transformers must be increased in order to improve the accuracy of the statistical analysis. This requires a concentrated effort from utilities and research institutions in order to get as much information as possible out of transformers during their scrapping process.

#### ACKNOWLEDGMENT

The authors would like to thank Dr. I. Höhle (Siemens AG) and H.-P. Gasser (Weidmann Transformerboard Systems AG) for analyzing paper samples and their fruitful discussion contributions.

#### REFERENCES

- [1] H. P. Moser and V. Dahinden, *Transformerboard II*. Rapperswil, Switzerland: H. Weidmann AG, 1987, CH-8640, S. 153/154.
- [2] A. Heisler and A. Banzer, "Zustandsbeurteilung von Transformatoren mit Furfurol-Bestimmung," Frankfurt, Germany, ew, Heft 16, Jg. 102, 2003, pp. 58–59.
- [3] X. Chendong, "Monitoring paper insulation ageing by measuring furfural contents in oil," presented at the 7th Int. Symp. High Voltage Eng., Dresden, Germany, Aug. 26–30, 1991, paper 74.06.
- [4] A. De Pablo, "Interpretation of furanic compounds analysis—Degradation models," Paris, France, 1997, CIGRE WG D1.01.03, former WG 15-01, Task Force 03.
- [5] A. B. Shkolnik and R. T. Rasor, "Statistical insights into furan interpretation using a large dielectric fluid testing database," presented at the IEEE Power Energy Soc. Transm. Distrib. Conf. Expo., Orlando, FL, May 2012.
- [6] T. Leibfried, M. Stach, N. Majer, I. Höhle, U. Thieß, J. Christian, M. Schäfer, K. Etkorn, H.-G. Schwabe, and W. Dewes, "Post mortem investigation of insulation material of power transformers and comparison with diagnostic measurements," CIGRE A-205 2008.
- [7] I. Höhle and A. J. Kachler, "Ageing of cellulose at transformer service temperatures. Part 1. Influence of type of oil and air on the degree of polymerization of pressboard, dissolved gases and furanic compounds," *IEEE Elect. Insul. Mag.*, vol. 21, no. 2, pp. 15–21, Mar./Apr. 2005.
- [8] I. Höhle and A. J. Kachler, "Ageing of cellulose at transformer service temperatures. Part 2. Influence of moisture and temperature on degree of polymerization and formation of furanic compounds in free-breathing systems," *IEEE Elect. Insul. Mag.*, vol. 21, no. 5, pp. 20–24, Sep./Oct. 2005.
- [9] L. Cheim, D. Platts, T. Prevost, and S. Xu, "Furan analysis for liquid power transformers," *IEEE Elect. Insul. Mag.*, vol. 28, no. 2, pp. 8–21, Mar./Apr. 2012.
- [10] S. V. Kulkarni and S. A. Khaparde, *Transformer Engineering, Design and Practice*. New York: Marcel Dekker, 2004.
- [11] S. Bhumiwat, S. Lowe, P. Nething, J. Perera, P. Wickramasuriya, and P. Kuansatit, "Performance of oil and paper in transformers based on IEC 61620 and dielectric response techniques," *IEEE Elect. Insul. Mag.*, vol. 26, no. 3, pp. 16–23, May/June 2010.
- [12] U. Sundermann and C. Neumann, "Life management von Hoch- und Höchstspannungstransformatoren," VDE Konferenz Diagnostik Elektrischer Betriebsmittel 9.-10.3.2004, ETG Band 97, pp. 103–108.

- [13] D. Allan, "Recent advances in the analysis and interpretation of aged insulation from operating power transformers," presented at the 5th Int. Conf. Properties Appl. Dielect. Mater., Seoul, Korea, May 25–30, 1997.
- [14] J. Unsworth and F. Mitchell, "Degradation of electrical insulating paper monitored using high performance liquid chromatography," in *Proc. Properties Appl. Dielect. Mater. Conf.*, 1988, pp. 337–340.
- [15] "Furanic compounds for diagnosis," CIGRE Tech. Brochure No. 494, Mar. 2012, CIGRE.

**Thomas Leibfried** (M'96) was born in Neckarsulm, Germany, in 1964. He received the Dipl.-Ing. and Dr.-Ing. degrees in electrical engineering from the University of Stuttgart, Germany, in 1990 and 1996, respectively.

From 1996 to 2002, he was with the Siemens AG, Nuremberg, Germany, working in the power transformer business in various technical and management positions. In 2002, he joined the University of Karlsruhe (now Karlsruhe Institute of Technology, KIT) as Head of the Institute of Electric Energy Systems and High-Voltage Technology (IEH). He is the author of more than 70 technical papers.

Prof. Leibfried is a member of VDE and CIGRE.

**Michael Jaya** was born in Kuala Lumpur, Malaysia, in 1982. He received the M.Sc. degree in electrical engineering from the Karlsruhe University of Applied Sciences, Karlsruhe, Germany, in 2008.

Since then, he has been a Research Fellow at the Karlsruhe Institute of Technology (KIT). His research interests include aging diagnostics of power transformers.

Mr. Jaya is a member of VDE.

**Norbert Majer** was born in Eschenbach, Germany, in 1968. He received the Dipl.-Ing. (FH) degree in electrical power engineering from the University of Applied Sciences, Regensburg, Germany, in 1993.

From 1993 to 2000, he was an Operating Engineer in a coal and gas power plant. In 2001, he changed to the Asset Management for control technology at E.ON Netz and in 2002, he changed to Asset Management for substations at E.ON Netz. Currently, he is responsible for the German power transformers of TenneT TSO GmbH.

Mr. Majer is a member of DKE and CIGRE.

**Michael Schäfer** was born in Backnang, Germany, in 1965. He received the Dipl.-Ing. and Dr.-Ing. degrees in electrical engineering from the University of Stuttgart, Stuttgart, Germany, in 1995 and 2000, respectively.

From 2000 to 2006, he was with Siemens AG, Nuremberg, Germany, in the transformer division. In 2006, he joined EnBW Regional AG and in 2011, he joined TransnetBW, Stuttgart. He is responsible for the innovation and technology of substations and transmission lines.

Dr. Michael Schäfer is a member of CIGRE and DKE.

**Manfred Stach** was born in Gelsenkirchen, Germany, in 1961.

Since 1987, he has been responsible for electrical projects in medium-voltage grids and power plants at VKR, Gelsenkirchen. Since 2000, he has been Head of the transformer team at EON Engineering, and since 2008, he has been Senior Expert for Transformers at EON Energy, Gelsenkirchen. He is Head of the PG Transformers at VGB Power Tech e.V., Essen, Germany.

Mr. Stach is a member of CIGRE and DKE.

**Stephan Voss** was born in Lübeck, Germany, in 1971. He received the Dr.-Ing. degree in electrical engineering from the University Erlangen-Nuremberg, Germany, in 2006.

He began work in R&D for Siemens, Nuremberg, Germany. Since 2007, he has been working for Siemens Transformers in research and development. Since 2011, he has been the Head of Fundamental Research, Siemens Power Transformer Factory, Nuremberg.